

2013 COOSA DISTRICT PINWOOD DERBYRACE RULES





2013 COOSA DISTRICT PINEWOOD DERBY RACE RULES



"The purpose of the Pinewood Derby is to help the Cub Scout build a team relationship with their parent or helper, experience the sense of accomplishment and the excitement of competition, learn Win/Lose good sportsmanship, and to have fun."

Source: usscouts.org

1.0 GENERAL RULES

- 1.1 The first rule of any Scouting event is to HAVE FUN and to ENJOY your experience. Please be aware of your surroundings when attending this event. We are guests and must adhere to any established rules.
- 1.2 We depend on these facilities or businesses for our continued success. Any business or facilities where we are a guest deserve our every courtesy. Follow the Scout Law and Oath at all times!

2.0 LOGISTICS

- 2.1 The District Derby is scheduled to be held on Saturday March 23rd at the Mount Berry Square Mall
- 2.2 Registration period is 8:00 a.m. to 10:00 a.m.
- 2.3 Entry Fee is \$5.00 + a can of food¹. The entry fee is to cover the costs of the patches, trophies, and door prizes
- 2.4 Races and judging are scheduled to begin at 10:00 a.m.
- 2.5 District Derby Format:
 - 2.5.1 District Championship Race
 - 2.5.2 District Best-of-Show
 - 2.5.3 District Open Class Race

¹ As part of the derby, the Coosa District Pinewood Derby Committee requests that each Scout participate in a canned food drive as part of the "Good Turn for America" campaign



2013 COOSA DISTRICT PINEWOOD DERBY RACE RULES



3.0 ENTRY QUALIFICATIONS & REQUIREMENTS

3.1 Cars must have been built during the current scouting year

3.2 Cars must have participated in a Pack's competition to take part in the District's Championship or Best-of-Show categories.

3.2.1 Cars racing in the District Championship Race must have placed 1st, 2nd, 3rd, or 4th at any qualifying Pack race.

- A Pack may designate an alternate to participate in the Championship Race should one of their 1st to 4th place finishers be unable to participate in the District's competition.

3.2.2 Cars competing in the District Best-of-Show must have placed 1st, 2nd, 3rd, or 4th at any qualifying Pack competition.

- A Pack may designate an alternate to participate in the Best of Show should one of their 1st to 4th place finishers be unable to participate in the District's competition.

3.2.3 Open class is open to all Cub Scouts that did not qualify for the District Championship Race through their Pack qualifying races or Packs that did not have a derby.

3.2.4 Only one car per Scout may be entered in the District's Derby. This means a Scout can compete with a single car in only one of the Derby's competitions (i.e., District Championship Race, District Best-of-Show, or the District Open Class Race).

3.2.5 All cars must meet the all of the specified requirements listed to compete in the District Championship Race, District Best-of-Show or the District Open Class Race.

4.0 GENERAL CAR REQUIREMENTS

4.1 The car must be propelled by gravity alone. No mechanical or artificial movement is allowed.



2013 COOSA DISTRICT PINWOOD DERBY RACE RULES



- 4.2 All cars, regardless of the competition they are entering, must meet the body, wheel, and axle requirements. This provides a level playing field for all of the competitions.

5.0 CAR BODY

- 5.1 Cars must be made from the official BSA car kit

5.2 Car Specifications & Measurements

- 5.2.1 Car Weight – Not to exceed 5.00 ounces
5.2.2 Car Width – Not to exceed 2.75 inches
5.2.3 Car Length – Not to exceed 7.00 inches
5.2.4 Car Height – Not restricted, but need to be able to clear the finish line. Guideline is 3.00 inches
5.2.5 Center Rail Clearance – 1.75 inches between the wheels
5.2.6 Bottom Clearance – Minimum underbody clearance of 0.375 inches is recommended to clear the center guide rails.

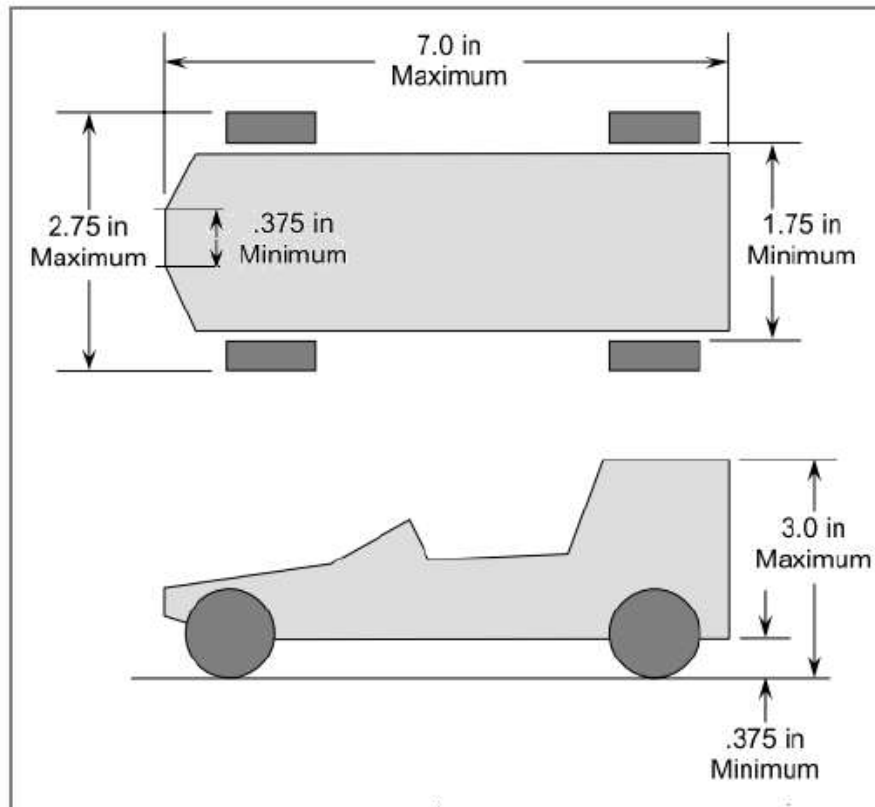



2013 COOSA DISTRICT PINewood DERBY RACE RULES



- 5.3 The original axle slots in the BSA car kit must be used
 - 5.4 No part of the car may extend past the starting pin, including wheels and add-ons.
 - 5.4.1 There must be a flat section of car that is at least 0.5 inch wide on the car's body and be at the center and front of the car. This portion of the car must be in contact with the starting pin.
 - 5.5 Only BSA official lights and noise makers are permitted on the car. No other electronics are permitted
 - 5.6 Items such as steering wheels, model drivers, spoilers, decals, painting and other details are permissible as long as these details do not exceed the maximum length, width, height, and weight specifications. Loose materials of any kind are not permitted on the car
- 6.0 WHEEL REQUIREMENTS
- 6.1 Wheels must spin freely. Nothing may alter the wheel's normal spin and rotation. No springs, magnets, mercury, propellants, or items serving a similar function may be used.
 - 6.2 Only BSA approved wheels may be used on the car.
 - 6.2.1 Wheels may be lightly polished or lightly sanded to remove normal molding imperfections. They may not be tooled or machined in any manner which will reduce the mass or weight, the initial inertia or the original shape of the wheel.
 - Determination of honing or machining a wheel so it becomes flat, convex or concave to minimize the surface-to-surface traction will be based on review by the Derby Committee.
 - 6.3 The BSA logo must be plainly visible on the outside of the wheel, the rippled edge shall be intact and hub area unmodified



2013 COOSA DISTRICT PINEWOOD DERBY RACE RULES

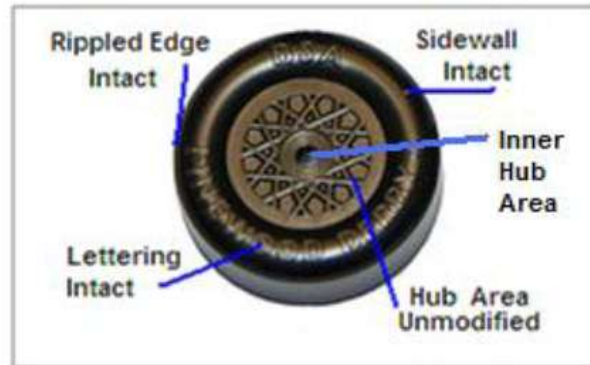

- 6.4 No object may be placed between the axle head and the wheel or between the wheel and the car body.
- 6.4.1 For example, no washers, bearings, bushings, sleeves may be used.
- 6.5 Cars must have 4 wheels. At least three wheels are to be in contact with the track at all times. Obvious alignment issues will be required to be adjusted prior to registering the car.
- 7.0 AXLE REQUIREMENTS
- 7.1 Only BSA approved axles may be used on the car. Axles included with the scout shop car kit are BSA approved axles.
- 7.1.1 However, axles may be polished in a manner to remove burrs and decrease friction from the wheel.
- 7.2 Axles are to be inserted into the car body parallel to the track surface. Axles inserted at a positive or negative angle, thus tilting the wheel so that it rides on the inner or outer edges is prohibited
- 7.3 The use of axle tubes, one piece axles, springs or bearings is prohibited
- 8.0 LUBRICANTS
- 8.1 Wet lubricants such as oils, silicones or waxes are prohibited.
- 8.2 Only graphite is to be used



2013 COOSA DISTRICT PINWOOD DERBY RACE RULES



- 8.2.1 Application of graphite is to be done in a manner so that it is not spilled inside the facility. Please ensure you add graphite outside, over a trash can, or other means to collect the excess or spilled amounts

9.0 INSPECTORS & DERBY COMMITTEE

- 9.1 The Derby Committee has the final review of all race car entries.
 - 9.1.1 The District's scale, measuring devices and/or track may differ from what was used at a Pack-level race. Weight or measurement issues directly related to a difference between the District's equipment and a Pack's equipment may be reviewed by the Derby Committee on a case-by-case basis.
 - 9.1.2 Every attempt will be made to qualify all cars during the registration process in accordance with the rules.
 - 9.1.3 Any issue as indicated above will be discussed between the Derby Committee and the entrant family in an attempt to resolve any such registration issues.
- 9.2 The Derby Committee does not provide tools, hot glue or other materials for car adjustments, nor advice on how to prepare (or repair) a race car so that it will pass the District's inspection.
- 9.3 All decisions of the Derby Committee are final with respect to the inspection process.
- 9.4 For questions or concerns related to these rules, please submit an e-mail to Pinewood Derby District Chair, Russ Foulke, at russfoulke@bellsouth.net so that they may be passed on to the Derby Committee to be reviewed and addressed. The Pinewood Derby Committee will make contact and discuss those concerns with the person who submitted the question or concern. The Committee's decision is final.